

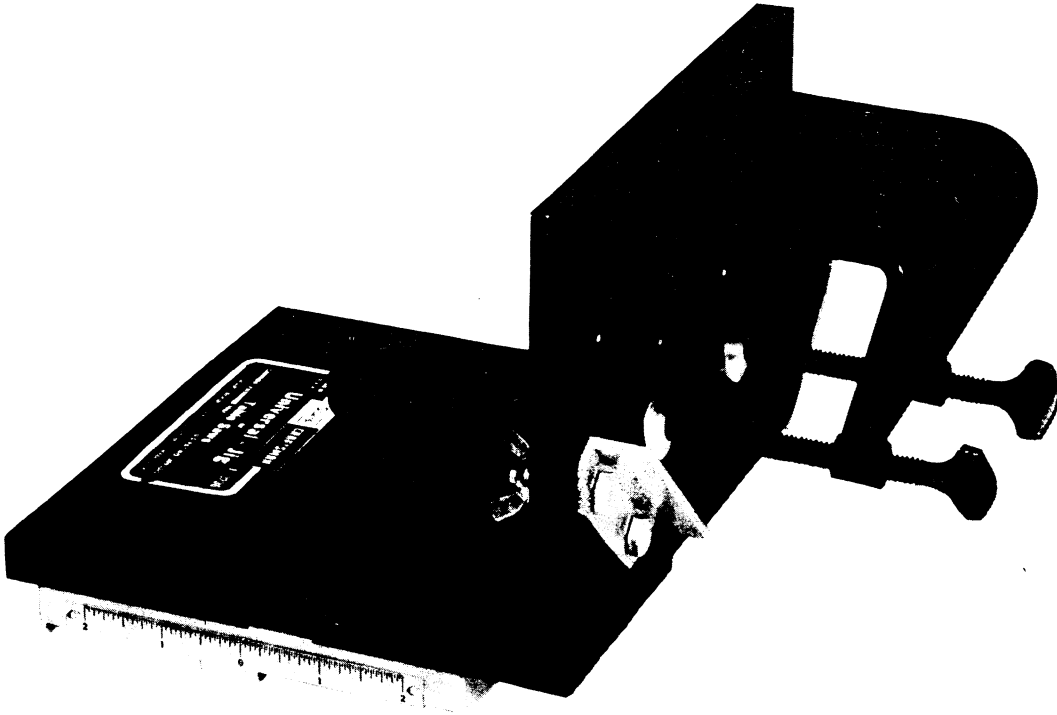

**INSTRUCTIONS FOR ASSEMBLY  
AND OPERATION OF YOUR  
UNIVERSAL JIG**

**9 3236**



## INTRODUCTION

Your Craftsman Universal Jig is essentially a work holding vise made for use on circular table saws which have  $\frac{3}{4}$ " wide miter slots in the table top — one slot on each side of the saw blade. The Universal Jig is designed to

hold material for making the difficult and dangerous end cuts for jointing, etc. etc. (The miter slots must be at least  $2\frac{1}{4}$ " from the saw blade. **Do not use the Universal Jig** if the slots are closer to the blade).

# GENERAL SAFETY INSTRUCTIONS FOR POWER TOOLS

- 1. KNOW YOUR POWER TOOL**  
Read the owner's manual carefully. Learn its application and limitations as well as the specific potential hazards peculiar to this tool.
- 2. GROUND ALL TOOLS (UNLESS DOUBLE INSULATED)**  
If tool is equipped with an approved 3-conductor cord and a 3-prong grounding type plug to fit the proper grounding type receptacle. The green conductor in the cord is the grounding wire. Never connect the green wire to a live terminal.
- 3. KEEP GUARDS IN PLACE**  
in working order, and in proper adjustment and alignment.
- 4. REMOVE ADJUSTING KEYS AND WRENCHES**  
Form habit of checking to see that keys and adjusting wrenches are removed from tool before turning it on.
- 5. KEEP WORK AREA CLEAN**  
Cluttered areas and benches invite accidents. Floor must not be slippery due to wax or sawdust.
- 6. AVOID DANGEROUS ENVIRONMENT**  
Don't use power tools in damp or wet locations or expose them to rain. Keep work area well lighted. Provide adequate surrounding work space.
- 7. KEEP CHILDREN AWAY**  
All visitors should be kept a safe distance from work area.
- 8. MAKE WORKSHOP KID-PROOF**  
— with padlocks, master switches, or by removing starter keys.
- 9. DON'T FORCE TOOL**  
It will do the job better and safer at the rate for which it was designed.
- 10. USE RIGHT TOOL**  
Don't force tool or attachment to do a job it was not designed for.
- 11. WEAR RIGHT APPAREL**  
Do not wear loose clothing, gloves, neckties or jewelry (rings, wrist watches) to get caught in moving parts. Non-slip footwear is recommended. Wear protective hair covering to contain long hair. Roll long sleeves above the elbow.
- 12. USE SAFETY GOGGLES (Head Protection)**  
Wear Safety goggles (must comply with ANS Z87.1) at all times. Also, use face or dust mask if cutting operation is dusty, and ear protectors (plugs or muffs) during extended periods of operation.
- 13. SECURE WORK**  
Use clamps or a vise to hold work when practical. It's safer than using your hand, frees both hands to operate tool.
- 14. DON'T OVERREACH**  
Keep proper footing and balance at all times.
- 15. MAINTAIN TOOLS WITH CARE**  
Keep tools sharp and clean for best and safest performance. Follow instructions for lubricating and changing accessories.
- 16. DISCONNECT TOOLS**  
before servicing; when changing accessories such as blades, bits, cutters, etc.
- 17. AVOID ACCIDENTAL STARTING**  
Make sure switch is in "OFF" position before plugging in.
- 18. USE RECOMMENDED ACCESSORIES**  
Consult the owner's manual for recommended accessories. Follow the instructions that accompany the accessories. The use of improper accessories may cause hazards.
- 19. NEVER STAND ON TOOL**  
Serious injury could occur if the tool is tipped or if the cutting tool is accidentally contacted.  
Do not store materials above or near the tool such that it is necessary to stand on the tool to reach them.
- 20. CHECK DAMAGED PARTS**  
Before further use of the tool, a guard or other part that is damaged should be carefully checked to ensure that it will operate properly and perform its intended function. Check for alignment of moving parts, binding of moving parts, breakage of parts, mounting, and any other conditions that may affect its operation. A guard or other part that is damaged should be properly repaired or replaced.
- 21. DIRECTION OF FEED**  
Feed work into a blade or cutter against the direction of rotation of the blade or cutter only.
- 22. NEVER LEAVE TOOL RUNNING UNATTENDED**  
Turn power off. Don't leave tool until it comes to a complete stop.

## ADDITIONAL SAFETY INSTRUCTIONS FOR UNIVERSAL JIG

1. Always feed the Jig all the way past the saw blade or cutter.
2. Never pull the Jig and workpiece back past the blade after making a cut. Always remove the Jig from the table after going completely past the blade.
3. Always clamp the workpiece with both clamps if at all possible.
4. Always tighten the workpiece securely with the clamps.
5. Always feed the Jig and workpiece through the cut slowly.
6. Never stand in line with the blade or cutter.

7. Always observe the safety instructions furnished by the manufacturer of your table saw. If you do not have those instructions, it is absolutely necessary to contact the manufacturer of your table saw and obtain a copy of the proper instructions. You must read and understand all instructions in their entirety before using the Universal Jig, or operating the saw.

8. Always be sure that the Jig is correctly resting on the saw table top with the protruding part of the base fully in the saw table miter slot before inserting and clamping the workpiece, or making a cut.

Failure to observe all safety rules could result in property damage and/or serious personal injury.

**9. WARNING.** THE TABLE SAW GUARD MUST BE REPLACED IMMEDIATELY AFTER COMPLETION OF THE OPERATION, IF THE OPERATION REQUIRED REMOVAL OF THE GUARD.

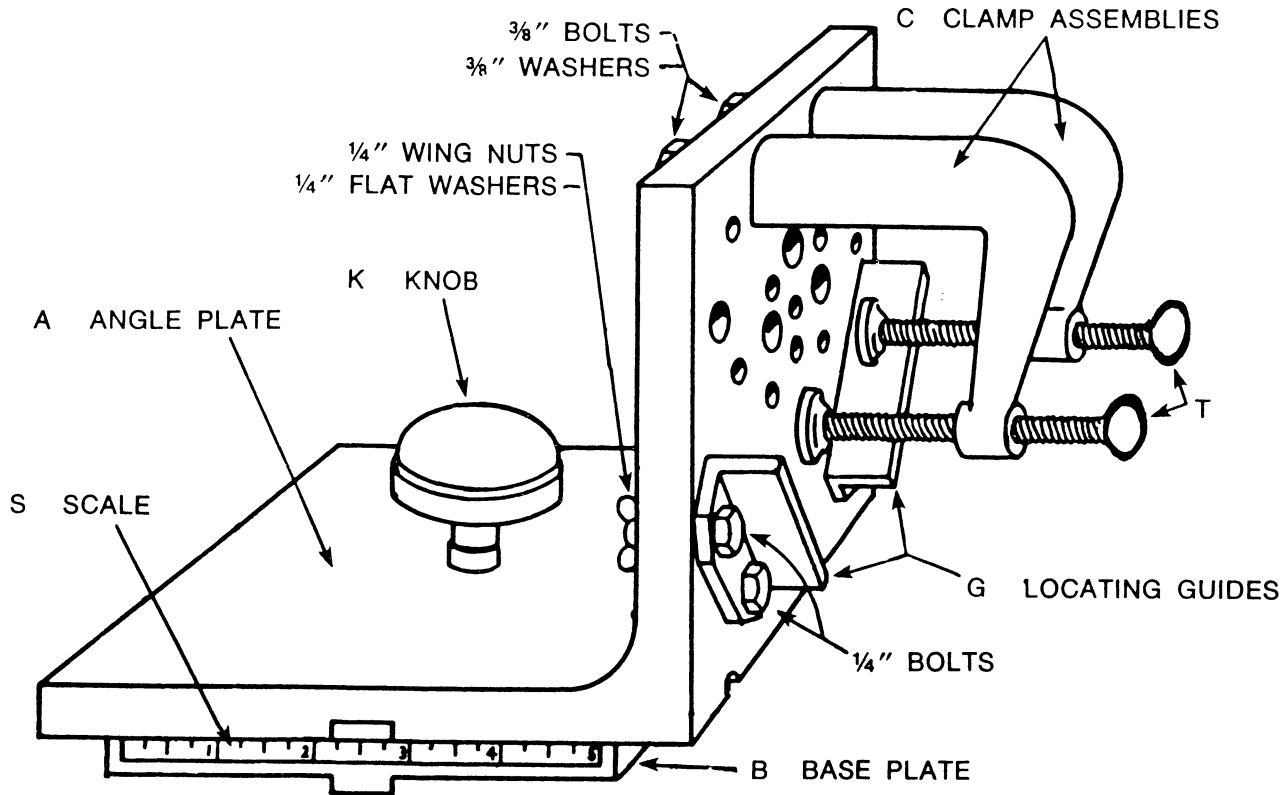

FIG. 1

COMPONENTS OF THE UNIVERSAL JIG ARE LISTED BELOW (REFER TO FIG. 1 FOR IDENTIFICATION).

Key	Description	Qty.	Key	Description	Qty.
A	Angle Plate	1		1/4" Flat washers	4
B	Base Plate	1		3/8" Bolts for Clamp assemblies	2
C	Clamp Assemblies	2		3/8" Washers to go under bolts	2
	Locating Guides	2	K	Knob for Clamping Base to angle plate	1
	1/4" bolts for locating guides	4	S	Scale on base plate	1
	1/4" wing nuts F/1/4" bolts	4			

The  $\frac{3}{4}$ " wide projection on the bottom of the base fits into the  $\frac{3}{4}$ " miter slot on the saw table. The knob "K", serves to tighten the base "B" to the angle plate "A". The knob also serves as the handle to grip the assembly while feeding slowly through the saw cut.

The vertical flat surface of the angle plate serves as the back-up for the workpiece. The location guides "G", can be bolted to the vertical surface of the angle plate in any of a number of positions, vertical or at  $45^\circ$ , using the  $\frac{1}{4}$ " bolts, washers and wing nuts. Be sure that each locating guide is attached to the angle plate with two (2) bolts. **(Never use the unit with only one bolt holding a locating guide to the angle plate).**

The clamps "C" are to be attached to the angle plate using a bolt and washer. (The bolt goes through the angle plate from the side opposite the flat surface). The clamps are attached through the hole in the angle plate which provides the best position for clamping the workpiece to the angle plate. Place the workpiece against the angle plate and a locating guide, then tighten the thumb screw securely. The photos below show how the workpiece, locating guides and clamps are typically positioned very clearly.

The angle plate can be used with the flat surface par-

allel to the saw blade and at a right angle to the saw blade. To rotate the angle plate 90 degrees on the base, loosen the knob "K" quite a number of turns until the angle plate can be lifted upwards from the base, and then rotated 90 degrees. After turning the angle plate 90 degrees, place back down against the base and tighten the knob "K". Be sure that the angle plate has "nested" flat against the base "B".

Loosening the knob "B" only slightly will permit you to move the angle plate towards or away from the saw blade in order to position the workpiece as desired relative to the saw blade.

The scale "S", is for convenience in measuring how far you move the angle plate to or fro. Be sure the knob "K" is securely tight and the thumb screws "T" are securely tightened against the workpiece before making any cuts.

When making cuts, hold the knob "K" firmly to feed the Universal Jig assembly along the miter slot in the saw table. Maintain pressure down against the table and against one edge of the miter slot in the saw table. Keep your hands away from the cutting area. The whole purpose of the jig is to hold workpiece firm so the operator can hold the knob "K", thus not endangering his hands.

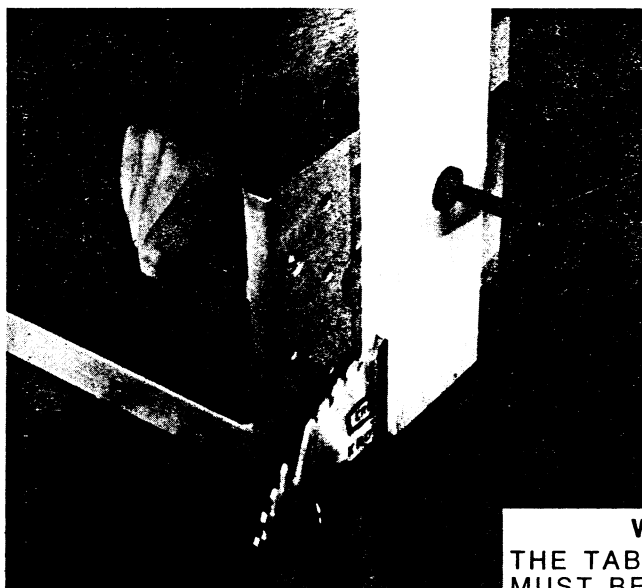

**END MORTISING**



**CUTTING TENNONS**

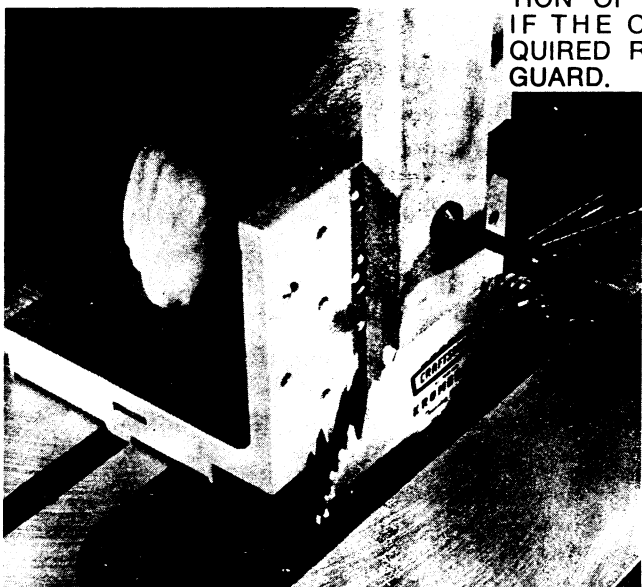

**MAKING LAP JOINTS**



**MAKING SPLINED JOINTS**

**WARNING**  
THE TABLE SAW GUARD  
MUST BE REPLACED IM-  
MEDIATELY AFTER COMPLE-  
TION OF THE OPERA-  
TION, IF THE OPERATION RE-  
QUIRED REMOVAL OF THE  
GUARD.